

SCHEDULE H PARKING REQUIREMENTS

SECTION 1.0 PURPOSE

It is the purpose of this Schedule to establish standards which promote the orderly, efficient, and safe layout of parking and loading areas and to minimize the necessity for impermeable surface areas.

SECTION 2.0 APPLICABILITY.

Off-street parking spaces shall be provided at the time of the development of any property, erection of any building or at the time any principal building is enlarged or increased in capacity by adding dwelling units, guest rooms, seats or floor area; or before the conversion from one (1) type of use or occupancy to another when the proposed use requires a greater number of parking spaces than the previous use,

Except as provided for under joint parking and shopping centers and malls, if a structure contains two (2) or more types of use, each use shall be calculated separately for the purpose of determining the number of total off-street parking spaces required.

The total number of parking spaces required shall be rounded off to the closest whole number if the computations based on this schedule result in any fractional requirement of a parking space. Fractional numbers ending in .5 shall be considered as the next whole space.

SECTION 3.0 UNSPECIFIED USES

The number of parking spaces for uses not specifically mentioned herein or unique cases shall be determined on an individual basis by the Planning and Zoning Commission. Factors to be considered in such determination include, but are not limited to, size of building, type of use, number of employees, expected volume and turnover of customer traffic, expected frequency and number of delivery and service vehicles and parking requirements for comparable uses specified in this schedule.

SECTION 4.0 JOINT USE OF PARKING FACILITIES

The Planning and Zoning Commission may authorize the joint use of parking facilities under the following conditions:

- A. **Shared Parking.** Up to fifty percent (50%) of the parking facilities of a use considered to be primarily a daytime use or a weekday use may be used to satisfy the parking facilities required by this section for a use considered to be primarily a nighttime use or a weekend use.
- B. **Covenant Required.** A covenant for any shared parking agreement shall be recorded in the office of the County Clerk, which shall include such reasonable conditions as the Planning and Zoning Commission may impose.

SECTION 5.0 REDUCTIONS AND INCREASES IN REQUIRED NUMBER OF PARKING SPACES

The Planning and Zoning Commission may reduce the number of required off-street parking spaces when the applicant demonstrates in a parking study prepared by a traffic engineer or traffic planner good cause or when the Commission finds that the applicant has demonstrated that a hardship exists regarding the development of the parcel. In such situations, the City may require land to be reserved for parking development should the use or needs change.

The Planning and Zoning Commission may approve an increase in the number of parking spaces up to twenty-five percent (25%) above the number required when the applicant demonstrates in a parking study prepared by a traffic engineer or traffic planner good cause.

SECTION 6.0 BICYCLE PARKING REQUIRED

- A. Purpose.** The purpose of this subsection is to provide adequate and safe facilities for the storage of bicycles.
- B. Applicability.** Bicycle parking facilities shall be provided for any new building, addition or enlargement of an existing building, or for any change in the occupancy of a building that results in the need for additional auto parking facilities.
- C. Exemptions.** No bicycle parking spaces shall be required for the following uses: single-family residence, two-family residence, funeral parlor, undertaker, cemetery, automobile repair or body shop, gas station and car wash.
- D. Bicycle Parking Spaces Required.** Off-street bicycle parking shall be provided as follows:
 - 1. For multi-family residences, there shall be one bicycle space or locker for every five (5) dwelling units or portion thereof.
 - 2. For all other uses, except exempted uses, one bicycle parking space shall be provided for every twenty (20) parking spaces required pursuant to Schedule H.
 - 3. In all cases where bicycle parking is required, a minimum of two (2) and a maximum of fifty (50) bicycle parking spaces shall be provided.
 - 4. The Administrative Official may reduce or eliminate the required number of bicycle parking spaces based on competent evidence provided by the applicant confirming that fewer bicycle parking spaces are required.
 - 5. A maximum of two (2) required vehicle parking spaces may be used for bicycle parking spaces.
- E. Location of Short Term Bicycle Parking Facilities.**
 - 1. **Visibility:** Cyclists should easily spot short-term parking when they arrive from the street. A highly visible location discourages theft and vandalism. Locations "off on the

side", "around the corner" or in un-supervised parking structures or garages shall be discouraged.

2. **Access:** The parking area should be convenient to building entrances and street access, but away from normal pedestrian and auto traffic. Locations that require bicycles to travel over stairs shall be discouraged.
3. **Security:** Surveillance is essential to reduce theft and vandalism. Parking shall be located within view of passers-by, retail activity, or office windows.
4. **Lighting:** Bicycle parking areas should be well lit for theft protection, personal security and accident prevention.
5. **Weather Protection:** Whenever possible, the bicycle parking area shall be protected from weather, using an existing overhang or covered walkway. Alternatively, a canopy or roof, either freestanding or attached to an existing building, shall be constructed.
6. **Avoid Conflict with Pedestrians:** Racks shall be located to ensure that parked bicycles don't block the pedestrian path.
7. **Avoid Conflict with Automobile:** Bicycle parking shall be separated from auto parking and road areas with space and a physical barrier to prevent motor vehicles from damaging parked bicycles.

F. Design of Parking Facilities.

1. The "Inverted U" type bike rack is the required bicycle parking rack for short-term parking. Any other type of proposed rack is subject to approval by the Administrative Official. Any such alternate security device submitted for approval must provide for:
 - a. Supporting the bike frame at two (2) locations (not just a wheel);
 - b. Allowing both the frame and at least one (1) wheel to be locked to the rack (without requiring that the lock be placed near the bicycle chain);
 - c. Allowing the use of either a cable or "U-type" lock;
 - d. Bicycles which are equipped with water bottle cages;
 - e. Bicycles which are not equipped with kickstands; and
 - f. All types and sizes of bicycles, including various types and sizes of frames, wheel sizes, and tire widths.
2. All lockers and racks must be securely anchored to the ground or the building structure to prevent the racks and lockers from being removed from the location.
3. The surfacing of such facilities shall be designed and maintained to be mud and dust free. The use of rock or gravel areas for bicycle parking is permitted provided that edging materials, such as landscape timbers are used so that the bicycle parking area is clearly demarcated and the rock material is contained.
4. Bicycle parking facilities shall be sufficiently separated from motor vehicle parking areas to protect parked bicycles from damage by motor vehicles. The separation may be

accomplished through grade separation, distance or physical barrier, such as curbs, wheel stops, poles or other similar features.

5. Required bicycle parking spaces shall be at least two (2) feet by six (6) feet per bicycle.
6. An aisle a minimum of five (5) feet wide shall be provided behind bicycle parking facilities to allow for maneuvering.
7. Sufficient space, to be a minimum of twenty-four (24) inches, shall be provided beside each parked bicycle to allow access. This access may be shared by adjacent bicycles. Racks shall be installed a minimum of twenty-four (24) inches from any wall or other obstruction.
8. It is recommended that one-half (1/2) of the bicycle parking spaces be provided as long term parking, safe and secure from vandalism and theft, and protected from the elements. The other half shall be provided as short term (customer or visitor) parking, and it is recommended that these parking spaces be visible and convenient to the building entrance.
9. Bicycle parking facilities shall be marked with a sign which includes a picture of a bicycle and the letter 'P' or the word 'Parking'.

G. Specifications for the "Inverted U" Type Bicycle Rack. The Inverted U's shall be fabricated from 1 ½" Schedule 40 Pipe, in accordance with ASTM F 1083, 48.26 mm O.D. x 3.683 mm wall (1.90" x 0.145" wall). The U's shall measure 914.4 mm high x 457.2 mm wide (36" high, 18" wide). The bicycle racks shall not be welded in sections. Only the base plate shall be welded to the steel pipe with two (2) 3mm (1/8") vent holes - one on the inside of each upright where the pipe is welded to the baseplate. After fabrication, the rack shall be coated with a Thermoplastic (polyethylene copolymer based) powder coating (polymer) to a thickness 200-250 micrometers (8 - 12 mils). Racks installed Downtown must be "Federal Green"- Color #14056 as specified in the Federal Paint Specifications 595B. Racks shall be mounted to concrete via 190 mm (7 ½") diameter baseplates 10mm (3/8") thick steel in accordance with ASTM A 36, with three 11 mm diameter (7/16") mounting holes on each base plate, spaced equidistant between the upright pipe and edge of the baseplate. Expansion anchor shall be carbon steel mushroom head, 10 mm x 76 mm (3/8" x 3") "spike" #5550 as manufactured by Rawl or approved equal manufactured in the U.S. made from grade 8.2 materials exhibiting equivalent theft-proof performance. Racks shall be set firm and aligned with a tolerance of plus or minus ¼" from plumb. Where required, steel tapered shims shall be installed prior to anchoring in place. Any departure of base plate from grade by more than 3/8" shall require the separation to be filled with high-strength epoxy non-shrinking grout and made level.

H. Long Term Bicycle Parking Facilities. Long term parking shall be provided for employees, bicycle commuters and tenants/owners in multifamily developments. Three common ways of providing secure long term bicycle parking are: fully enclosed lockers accessible only by the user; a continuously monitored facility that provides at least medium term type bicycle parking facilities; and restricted access facilities in which short term type bicycle racks are provided and access is restricted only to the owners of the bicycles stored therein. The easiest retrofit is the bicycle locker. Bicycle lockers are designed to be secure individual bikes with panniers,

computers, lights, etc, left on the bike. Some designs of bike lockers can be stacked so there is twice the parking density. Good protection from the weather is another benefit. Bike lockers tend to be used most for long term bicycle commuter parking in areas without a lot of continuous oversight.

SECTION 7.0 OFF-STREET PARKING REQUIREMENTS

A. Number of Automobile Parking Spaces.

LAND USE CATEGORY		MINIMUM NUMBER OF PARKING SPACES REQUIRED PER INDICATED UNIT	UNIT OF MEASURE
RESIDENTIAL	One-Family Dwelling	2.0	Per Dwelling Unit
	Mobile Home	2.0	Per Dwelling Unit
	Multiple-Family Dwelling	2.0	Per Dwelling Unit
	Townhouse	2.0	Per Dwelling Unit
MISCELLANEOUS	Travel Trailer	1.0	Per Travel Trailer
	Day Care Facility	4.0	Per 1,000 square feet Gross Floor Area (GFA) ¹
	Residential Care Facility	1.0	Per 3 beds
	Boarding House	1.0	Per Sleeping Room
	PLUS	1.0	Per Resident Manager
	Accessory Dwelling Unit; Accessory Residential Structure; Accessory Agricultural Housing	1.0	Per unit
PUBLIC AND SEMI-PUBLIC	Noncommercial Amusement Facility		
	Indoor/Outdoor with fixed seating	1.0	Per seat or per person based on maximum capacity
	Without fixed seating	1.0	Per 100 square feet of GFA and/or Land Area devoted to Assembly or Recreation Use on the premises
	Educational Facilities		
	Elementary School and Middle School	1.0	Per 9 students of maximum design capacity
	High School, College, University or Vocational School	1.0	Per 4 students of maximum design capacity
	Library	3.0	Per 1,000 square feet of GFA
	Cultural Facility		
	Indoor	1.0	Per 1,000 square feet of GFA
	Outdoor	1.0	Per acre of facility
House of Worship	1.0	Per 3 seats based on maximum capacity of Auditorium Or Principal Place of Assembly	

LAND USE CATEGORY		MINIMUM NUMBER OF PARKING SPACES REQUIRED PER INDICATED UNIT	UNIT OF MEASURE
PUBLIC AND SEMI-PUBLIC Continued	Hospital	1.4	Per bed based on maximum patient capacity
	Government Uses	<u>1.0</u>	Per parking space required based on non-government use of the same type
COMMERCIAL	General Retail Sales and Service Indoor including commercial schools	5.0	Per 1,000 square feet of GFA
	Convenience Store	7.0	1,000 square feet of GFA
	Retail, Large Goods	3.0	1,000 Square Feet of GFA
	Multi-tenant Shopping Center or Mall		
	100,000 square feet or less;	4.0	1,000 square feet of GFA
	Greater than 100,000 square feet	3.0	1,000 square feet of GFA
	Outdoor Display-New Merchandise; New and Used Vehicular Dealers;	1.0	Per 1,000 square feet of Gross Sales and Storage Area (interior and exterior)
	Outdoor Display-Used Merchandise;		
	Outdoor Storage		
	Business And Professional Offices	4.0	Per 1,000 square feet of GFA
Medical and Dental Office	5.0	Per 1000 square feet of GFA	
Restaurant	1.0	Per 3 seats based on maximum customer capacity	
Fast Food Restaurant with Drive-through lane	1.0	Per 5 seats based on maximum customer capacity	
Self-Storage Facility	6.0	Adjacent to the office; and temporary loading zones must be provided on each side of the driving lanes that are adjacent to the storage buildings. Buildings must be 24 feet apart if 1 parking lane is provided and 32 feet apart if 2 parking lanes are provided.	
TRANSIENT LODGING AND ENTERTAINMENT	Transient Lodging Establishment	1.0	Per Sleeping Unit
	PLUS	.2	Per restaurant seat or conference room based on maximum customer capacity
	Commercial Amusements: Indoor/Outdoor		
	With Fixed Seating	1.0	Per 4 seats based on maximum capacity
Without Fixed Seating	1.0	Per 200 square feet of floor and/or land area devoted to assembly or recreational use on the premises	
	Health Club	10.0	Per 1,000 square feet GFA

LAND USE CATEGORY		MINIMUM NUMBER OF PARKING SPACES REQUIRED PER INDICATED UNIT	UNIT OF MEASURE
AUTOMOTIVE	Automobile And Truck Service; Automobile And Truck Repair; Automobile And Truck Rental; Automobile Rental Office; Major Equipment Rental; Major Equipment Repair; Automobile And Truck Accessory Sales and Installation	3.0	Per 1,000 square feet of GFA.
MISCELLANEOUS BUSINESS & SERVICES	Funeral Home, Mortuary And/Or Crematory	1.0	Per 4 seats based on maximum capacity of funeral service chamber or chapel
	Laundry And Dry Cleaning Plant	1.0	Per 1,000 square feet of GFA
	Domestic And Business Service; Landscaping Service Establishment	3.0	Per 1,000 square feet of GFA
	Auction Sales Establishment Inside	1.0	Per 4 seats based on maximum capacity of place of assembly
	Outside	1.0	Per 50 square feet of area devoted to assembly on the premises
	Veterinarian And Animal Hospital; Animal Boarding Kennel	3.0	Per 1,000 square feet of GFA
	Welding Establishment	1.0	Per 1,000 square feet GFA
INDUSTRIAL	Wholesale And Storage	1.0	Per 1,000 square feet of GFA
	Manufacturing	2.0	Per 1,000 square feet of GFA
	Junk Yard	1.0	Per Acre of Facility
AGRICULTURAL	Agriculture Animal Raising	1.0	Per acre of facility

¹ Gross Floor Area (GFA): The sum of the horizontal areas of the stories of a building or buildings, measured from the exterior faces of exterior walls or from the centerlines of walls which separate buildings. Included within such sum shall be the areas of all stories, including those areas which are not heated or air-conditioned, storage areas, interior balconies and mezzanines, and any other space reasonably usable for any purpose except parking.

- B. Parking in the Special Commercial Zoning District (SC-3).** There shall be no off-street parking requirements for existing buildings in the SC-3 zoning district.
- C. Maximum Number of Parking Spaces.** No development shall exceed the required number of parking spaces by more than twenty five percent (25 %).

- D. Parking of Company Vehicles.** The minimum off-street parking space requirements for trucks and other similar company vehicles shall be one (1) space for every vehicle operated by the establishment on the premises and for automobiles as shown in Schedule H, Minimum Automobile Off-street Parking Space Requirements; provided however, that there shall be no off-street space requirements for existing buildings when such uses are located in an SC-3, Special Commercial Zoning District. The number of off-street parking spaces for company vehicles shall be evaluated and approved by the Administrative Official.
- E. Off-Street Parking Structures.** All off-street parking structures designed to accommodate five (5) or more vehicles shall comply with all area and dimension regulations for principal buildings as well as all off-street parking area buffer strip requirements included herein. All off-street parking structures designed to accommodate four (4) or less vehicles, shall be considered as accessory buildings unless attached to a principal building. If attached to a principal building, such off street parking structures shall be subject to all the regulations of these land development regulations for principal buildings and, if detached, such off-street parking structures shall be subject to all the regulations contained herein for accessory buildings.

SECTION 8.0 PARKING LOT DESIGN STANDARDS

- A. Location of Parking Areas.** Off-street parking area including required parking spaces, accessways, buffers and related off-street parking appurtenances, shall be provided for all buildings and uses on the premises; or, if approved by the Planning and Zoning Commission, such off-street parking may be located a maximum distance of three hundred feet (300') from the premises it serves and/or may be consolidated into a large parking area serving other buildings and uses provided that such off-street parking space shall be maintained, regulated and enforced as if it were actually located on the premises it is designed to serve.

The applicant must provide a binding plan, deed or other proof necessary to show that the required parking space, if approved to be located off the premises it serves, is controlled by and available to, the applicant for as long as the use it is intended to serve is in existence.

- B. Design of Parking Areas.** All parking area designs shall comply with Figure H-1 of this Schedule.
- C. Internal Circulation of Parking Areas.**
1. The internal design of the parking area shall be designed to facilitate vehicular circulation and avoid conflict between pedestrian and vehicular movements. Internal circulation also shall be designed so as not to create conflict with access into or egress from the site and shall be consistent with the landscape requirements of these land development regulations.
 2. Each parking stall shall be accessible from an aisle or driveway and designed so that no automobile shall back into a public street in order to exit a parking stall.

3. **Parking Aisle Width.** Minimum access way shall be twelve (12) feet for one-way traffic and twenty-four (24) feet for two-way traffic.

D. Size of Parking Stalls. The minimum size of parking spaces shall be as follows:

Regular (non-handicapped):	10 feet (10') wide;	20 feet (20') long;
Parallel:	9 feet (9') wide;	20 feet (20') long;
Handicapped:	12 feet (12') wide;	20 feet (20') long.

E. Design of Parking Stalls. All paved parking stalls shall have four inch (4") white lines between spaces to indicate individual stalls, and each stall may be required to be equipped with wheel stops if deemed appropriate by the Planning and Zoning Commission based upon competent evidence.

Wheel stops for stalls adjacent to landscaped strips shall be located two and one-half (2½) feet from the front end of the stall to prevent encroachment into required landscaped areas. The front two (2) feet of the stall may be kept as a maintained vegetative ground cover area although no credit will be extended toward the open space requirements of these regulations.

F. Paved Parking and Dimensional Standards. All required parking spaces and vehicular use areas shall be paved.

1. Asphaltic paving shall provide a one (1) inch thick asphalt surface, a four (4) inch thick base and a six (6) inch thick subgrade.
2. Concrete paving shall provide a five (5) inch thick Portland concrete surface with a compressive strength of 3,000 p.s.i. and a subgrade with a Fla. Bearing Value of 75 p.s.i.
3. Such paved areas shall be provided with positive drainage and shall not permit ponding depth of greater than one-eighth (1/8) inch.
4. Curbing or bumper stops shall be provided to protect all required landscaped areas and buildings.
5. All parking spaces shall be striped white. Such striping shall be a minimum of four (4) inches wide and shall conform to the FDOT's Standard Specifications for Road and Bridge Construction, latest edition.

All striping and other traffic control devices shall conform and be maintained to the latest edition of the Manual on Uniform Traffic Control Devices. Painted wooden regulatory signs shall not be deemed to comply with these regulations. All driveways exiting on to any public or private street shall be controlled by a High Intensity thirty (30) inch stop sign. Twenty-four (24) inch stop signs shall be used internally. The clearance from the finished ground elevation to the bottom of all signs shall be at least seven (7) feet. All handicap parking spaces shall be in accordance with the Florida Department of Community Affairs Accessibility Requirements Manual.

6. Required parking spaces and vehicular use areas for residential uses with less than ten (10) required parking spaces may utilize a substitute surface for such off-street parking and vehicular use areas. Such surface shall be specified in terms of thickness and other relevant characteristics, must be maintained continuously in an approved condition and approved by the Administrative Official. If the substitute surface is not maintained properly, the Administrative Official shall have the authority to take actions necessary to insure that the area in question is paved in a manner that conforms to the requirements of this Schedule and that all actions to that end shall be at the sole expense of the owner. Small-scale nonresidential uses may request from the Administrative Official to utilize a substitute surface for off-street parking and vehicular use areas in accordance with this Code.

G. Fire Lane Pavement Striping and Signage Standards. Buildings and sites which are required to include fire lanes shall comply with the following standards.

1. **Pavement Striping.** Fire lane pavement striping shall be yellow and painted of thermoplastic or an equivalent substitute. The perimeter of the striping shall begin at the curb and extend to a width of eight (8) feet parallel to the curb. The perimeter lines and required striping within the perimeter shall be four (4) inches wide with a ten (10) inch space between stripes. The stripes shall not be painted over or under the painted words required below.
2. **Painted Letters on Pavement.** The words "NO PARKING FIRE LANE" shall be painted within the perimeter of the fire lane striping. The stroke of each letter shall be four (4) inches wide and shall be painted in yellow FDOT traffic-rated reflective paint. Each repeated phrase shall be painted not more than one hundred (100) feet apart.
3. **Signs.** Fire lane signs shall be installed not more than one hundred (100) feet apart and shall contain the words "NO PARKING FIRE LANE". The background and lettering of signs shall have a high intensity reflective facing.
4. **Relationship of Pavement Lettering and Sign Locations.** Pavement lettering and signs shall be staggered in location so that each are not more than fifty (50) feet apart.
5. **Curb Painting.** All curb facing shall be painted yellow for the entire length of the fire lane using a FDOT traffic-rated reflective paint.

SECTION 9.0 HANDICAPPED ACCESS.

Parking spaces designated for physically handicapped people and accessible passenger loading zones that serve a particular building shall be located on the shortest possible circulation route to an accessible entrance of the building. In separate parking structures or lots that do not serve a particular building, parking spaces for physically handicapped people shall be located on the shortest possible circulation route to an accessible pedestrian entrance of the parking facility.

A. Parking Spaces.

1. Any commercial real estate property owner offering parking for the general public shall provide specially designed and marked motor vehicle parking spaces for the exclusive use of physically disabled persons who have been issued parking permits pursuant to Sections 316.1958, 320.0842, 320.0843, 320.0845 or 320.0848, Florida Statutes.
2. Diagonal or perpendicular parking spaces shall be a minimum of twelve (12) feet wide, as illustrated in Figure H-2, Handicap Sign and Parking Space Standards.
3. Parallel parking spaces shall be located either at the beginning or end of a block or adjacent to alley entrances as illustrated in Figure H-3, Passenger Loading Zones.
4. Each such parking space shall be conspicuously outlined in blue paint, and shall be posted and maintained with a permanent, above-grade sign bearing the international symbol of accessibility or the caption "PARKING BY DISABLED PERMIT ONLY," or bearing both such symbol and caption as illustrated in Figure H-2, Handicap Sign and Parking Space Standards. Such signs shall not be obscured by a vehicle parked in the space. All handicapped parking spaces must be signed and marked in accordance with the standards adopted by the Department of Transportation.
5. All spaces shall have an adjacent access aisle sixty inches (60") wide minimum, as illustrated in Figure H-2, Handicap Sign and Parking Space Standards. Parking access aisles shall be part of the accessible route to the building or facility entrance and shall comply with the Accessible Route section of the Florida Board of Building Codes and Standards, Accessibility Requirements Manual. Two (2) accessible parking spaces may share a common access aisle. Parked vehicle overhangs shall not reduce the clear width of an accessible circulation route.
6. All spaces shall have access to a curb-ramp or curb-cut, when necessary to allow access to the building served, and shall be located so that users will not be compelled to wheel behind parked vehicles.
7. The minimum number of such parking spaces shall comply with the following table:

<u>Total Number of Parking Spaces in Lot</u>	<u>Required Number of Accessible Spaces</u>
Up to 25	1
26 to 50	2
51 to 75	3
76 to 100	4
101 to 150	5
151 to 200	6

201 to 300	7
301 to 400	8
401 to 500	9
501 to 1000	2% of Total
Over 1000	20 plus 1 for each 100 over 1000

B. **Passenger Loading Zones.** Passenger loading zones shall provide an access aisle at least forty-eight (48) inches wide and twenty (20) feet long adjacent and parallel to the vehicle pull-up space as illustrated in Figure H-3, Passenger Loading Zones. If there are curbs between the access aisle and the vehicle pull-up space, then a curb ramp complying with the Curb Ramp section of the Florida Board of Building Codes and Standards, Accessibility Requirements Manual shall be provided.

A minimum vertical clearance of one hundred eight (108) inches shall be provided at accessible passenger loading zones and along vehicle access routes to such areas from site entrances.

SECTION 10.0 REQUIRED OFF-STREET LOADING AND SERVICE AREAS

A. **Required Area.** Off-street loading and service area space shall be provided on the premises of all public and semipublic, commercial, transient lodging and entertainment, automotive, miscellaneous business and services, industrial and agricultural processing establishment uses so that no loading, unloading or servicing of buildings by refuse collection, fuel or other public or private service type vehicular activity will be generated on any required off-street parking space or on any street. Each required off-street loading, unloading and service area space shall be at least sixty (60) feet in depth, unless competent evidence is provided to the Administrative Official to include a certification by a licensed Florida professional engineer, twelve feet (12') in width, with an overhead clearance of not less than sixteen (16) feet for each such space required; or, if approved by the Administrative Official, a total area at finished grade of at least seven hundred twenty (720) square feet devoted to such use with an overhead clearance of not less than fourteen feet (14') for each such space required regardless of actual space dimensions and design.

B. **Arrangement.** The off-street loading, unloading and service area space shall be arranged so that it may be used without blockage or interference with the use of adjacent streets, accessways or off-street vehicular or pedestrian traffic circulation.

C. **Number of Spaces.** The Administrative Official shall interpret and approve the amount of loading, unloading and service area space required for all public and semi-public, commercial, transient lodging and entertainment, automotive, miscellaneous business and services, industrial and agricultural processing establishment uses based on the following total gross floor area of each building located on the premises:

<u>Gross Floor Area</u> (Square Feet)	<u>Number of Loading Spaces</u>
5,000-25,000	One (1) Space.
25,001-60,000	Two (2) Spaces.

60,001-120,000
Each additional 100,000 square feet,
or major fractional thereof

Three (3) Spaces.
One (1) Additional Space.

- D. **Building Alterations.** The City shall determine the amount of off-street loading, unloading, and service area for commercial uses based on a building's gross usable floor area and not the net usable floor area so as to accommodate any future alterations in the use of interior space.

SECTION 11.0 RECREATIONAL VEHICLES AND ASSOCIATED EQUIPMENT STORAGE IN TOWNHOUSE AND MULTI-FAMILY RESIDENTIAL DEVELOPMENTS

In the case of multi-family and townhome residential developments, the storage of recreational and other such equipment shall be regulated as follows:

- A. All multi-family and townhome developments with more than twenty-five (25) dwelling units shall provide a designated area for the parking and storage of recreational vehicles, boats and equipment.
- B. The designated area shall be at a distance as remote as practical and in accordance with sound and generally accepted design and land use practices and principles from the dwelling units. The parking area for boats, trailers, jet skis and similar types of equipment shall be screened with plant material, decorative walls, fences, berms or any combination thereof, in an effort to diminish any visual impact that the area may have on the rest of the site. Parking for recreational vehicles need not be screened.
- C. The designated area shall be a paved surface consistent with the rest of the parking area within the development and shall provide ample ingress and egress and space for easy maneuverability for the type of vehicles and equipment using the area.
- D. Each multi-family and townhome development shall provide a minimum of one (1) space per twenty-five (25) dwelling units for the purpose of parking and storing recreational vehicles and equipment. Any fraction of twenty-five (25) shall require spaces rounded up to the next whole number.

SECTION 12.0 DRIVE-THROUGH LANES AND STACKING DISTANCES

- A. **Drive-through Requirements.** Drive-through lanes and windows shall be designed to the following standards:
1. Drive through windows and lanes shall not be located on a side of the building fronting a street.
 2. Hedges. A dense hedge of evergreen shrubs shall be provided in the following manner:

- a. At initial planting and installation, shrubs shall be at least thirty (30) inches in height and shall be planted thirty (30) inches or less on center.
- b. Within one (1) year of initial planting and installation, shrubs shall have attained, and be maintained at, a minimum height of four (4) feet and shall provide an opaque vegetative screen between the street and the drive-through. The hedge must continue for the entire length of the drive-through cueing or stacking area.
- c. In lieu of a vegetative hedge, the use of vegetated berms with appropriate landscape materials may be used in a manner that results in the visual separation of street right-of-way and the drive-through.

B. Stacking Distance. The following minimum stacking distances, measured from the point of entry to the center of the farthest service window area, are required:

Restaurants, full service car washes, day care facilities:	Two hundred twenty feet (220')
Banks (per lane):	One-hundred seventy six feet (176')
Self Service Car Wash (per bay) and Dry Cleaners:	Sixty-six feet (66')

Facilities not listed above with more than one drive-through lane shall provide one hundred (100) feet of stacking distance per lane measured from the point of entry to the center of the farthest service window area. In all other cases, the Administrative Official shall have the authority to determine the stacking distance for other uses on a case-by-case distance based upon the application of sound engineering practices and principles.

The drive-through lane shall be a separate lane from the circulation routes and aisles necessary for ingress and egress from the property or access to any off-street parking spaces.

For lanes greater than one hundred seventy-five feet (175') a pass-through lane shall be constructed adjacent to at least one (1) stacking lane in order to provide a way out of the stacking lane.

SECTION 13.0 PARKING CALCULATIONS REQUIRED

All applications for development approval shall include parking calculations indicating the required number of parking spaces required pursuant to this Schedule.

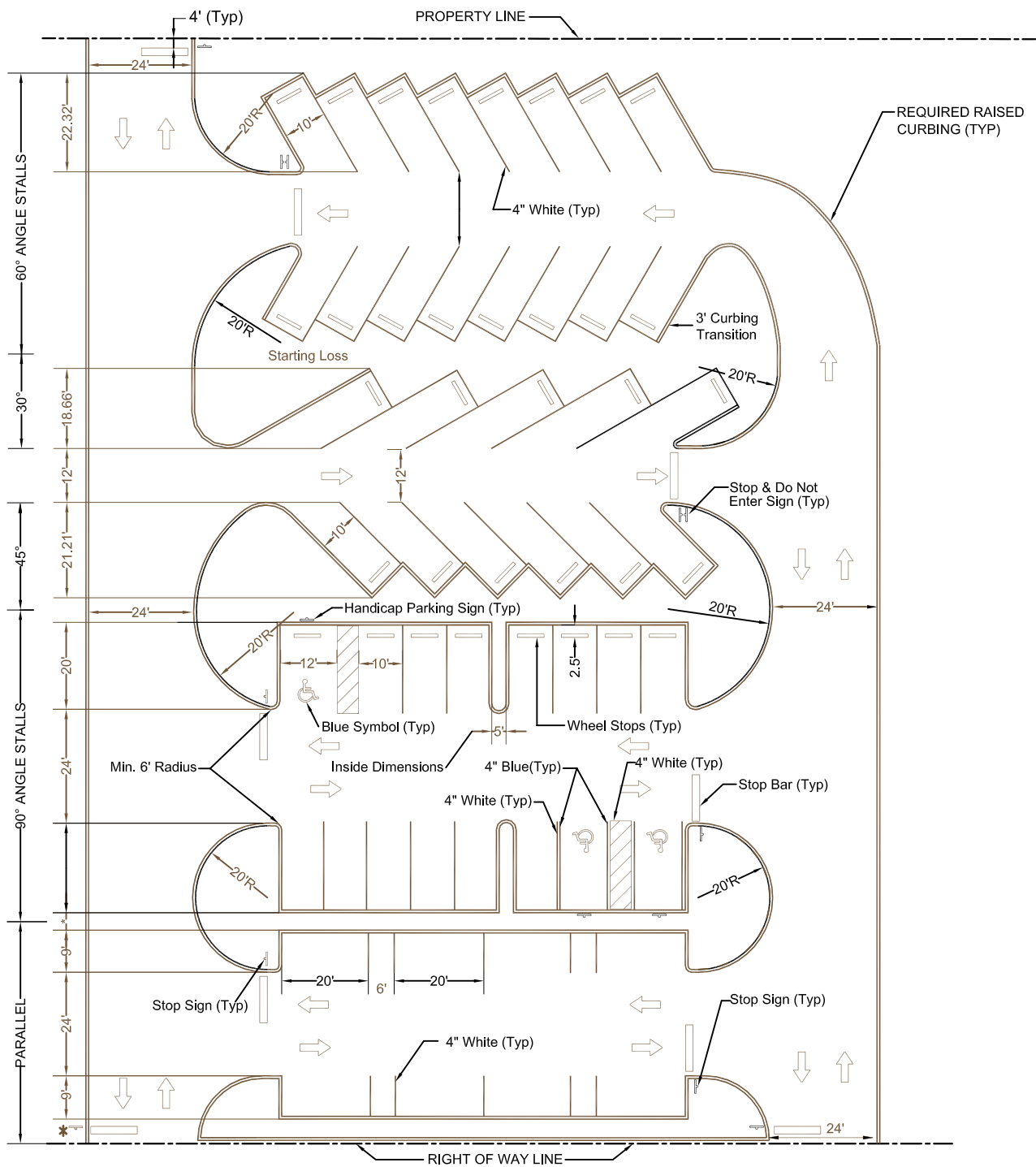

NOTES:

1. Minimum requirements shown.
2. All signage shall comply with the Manual on Uniform Traffic Devices.

PARKING ANGLE	CURB LENGTH	STALL DEPTH	STARTING LOSS	LAST CAR REQUIREMENTS	AISLE WIDTH	
					12'	24'
30°	20'	18.66'	32.32'	5.00'	12'	24'
45°	14.14'	21.21'	21.21'	7.07'	12'	24'
60°	11.55'	22.32'	12.88'	8.66'	17'	24'
90°	10'	20'	5' MIN	10.00'	24'	24'

ONE WAY : TWO WAY



**City of Sanford
Department of Planning &
Development Services**

PARKING STANDARDS

Date: AUGUST 2004

Drawn By: M. JONES

**FIGURE
H-1**

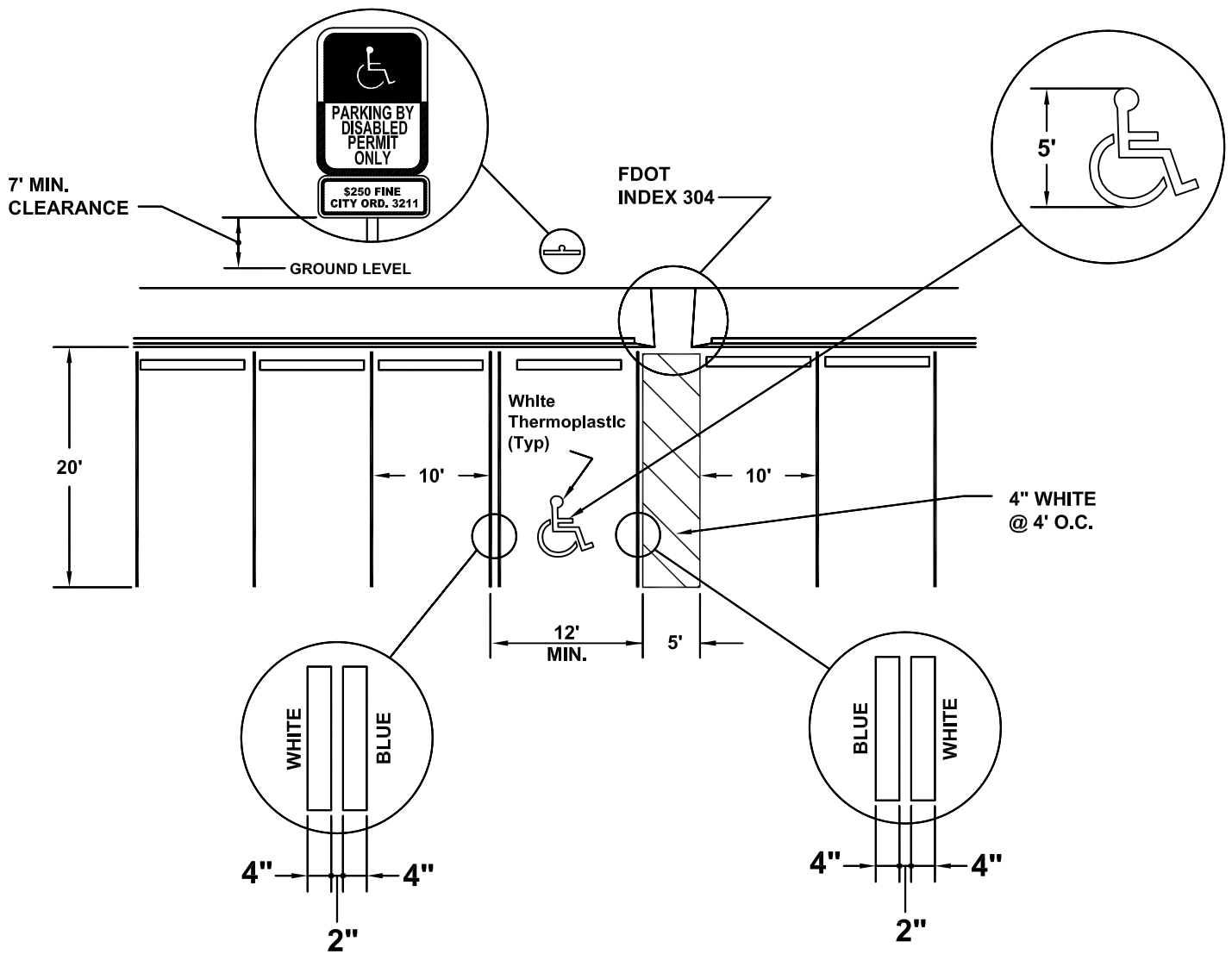

**FIGURE H-2
HANDICAP SIGN & PARKING SPACE
STANDARDS**

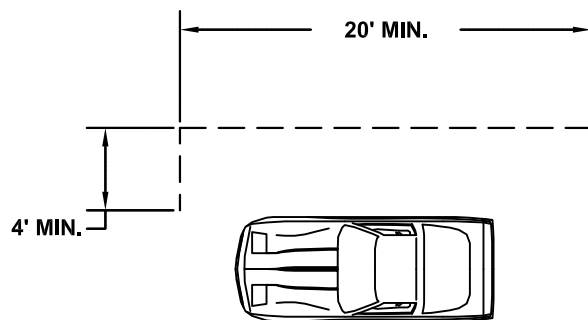

**FIGURE H-3
PASSENGER LOADING ZONES**



**City of Sanford
Department of Planning &
Development Services**

**HANDICAP SIGN/PARKING
& PASSENGER
LOADING ZONES**

Date: 6/29/2011

Drawn By: M. JONES

**FIGURE
H-2
H-3**