

**SINGLE SERVICE**

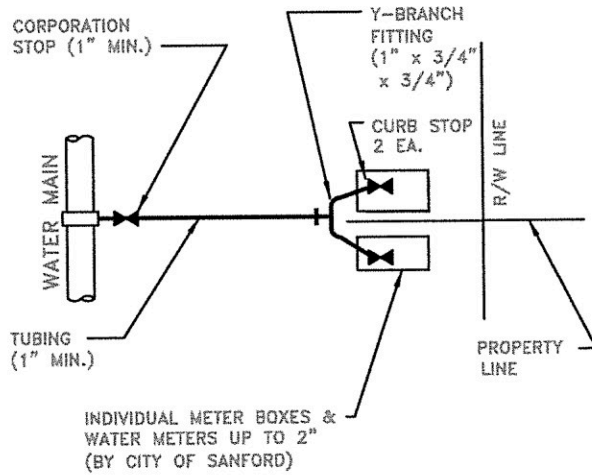

**DOUBLE SERVICE**

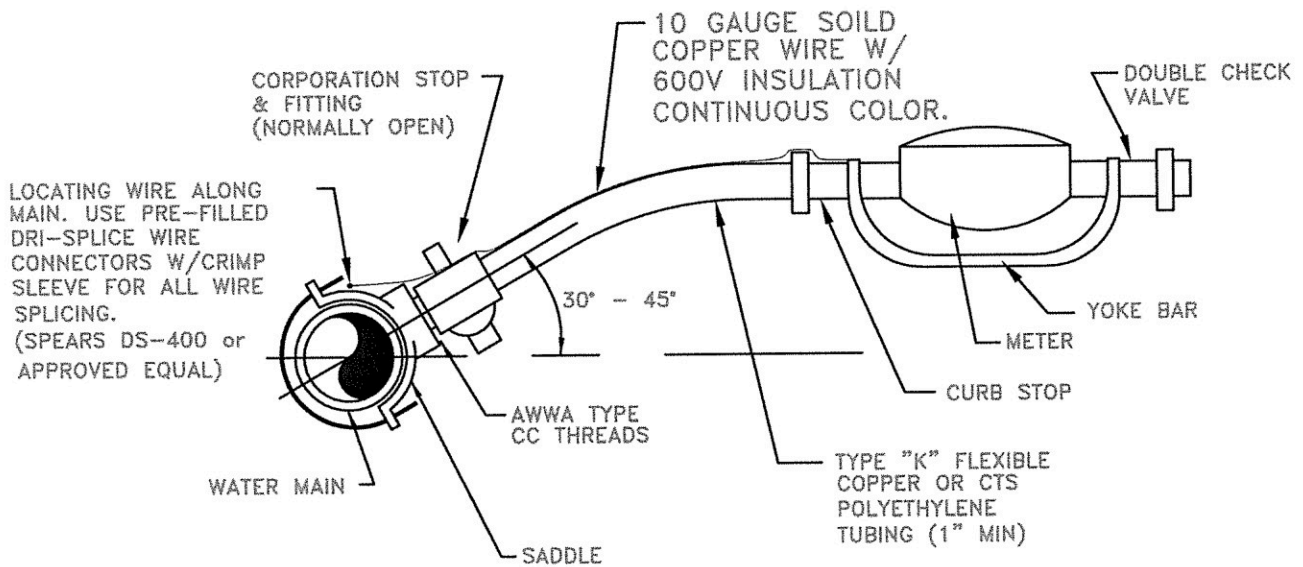

**NOTES:**

1. ALL FITTINGS SHALL BE BRASS WITH COMPRESSION/PACK JOINT TYPE CONNECTIONS.
2. NO SERVICE LINE SHALL TERMINATE UNDER A DRIVEWAY.
3. EACH SERVICE SHALL TERMINATE AT A CURB STOP(S) WHICH SHALL BE BURIED APPROXIMATELY 3" BELOW FINAL GRADE AND SHALL BE CLEARLY MARKED WITH A 2" x 2" x 18" STAKE WITH THE TOP PAINTED BLUE AND MARKED WITH THE NUMBER OF THE LOT(S) TO BE SERVED.
4. RECLAIMED WATER SERVICES SHALL BE PAINTED PURPLE (COPPER) OR USE PURPLE COLORED CTS POLYETHYLENE TUBING.
5. POTABLE WATER SERVICES SHALL BE PAINTED BLUE (COPPER) OR USE BLUE COLORED CTS POLYETHYLENE TUBING.

**WATER SERVICE CONNECTION DETAIL**