

1. MANUFACTURE DATE SHALL BE VISIBLE ON OUTSIDE OF TANK. (CURE TO 4000PSI @ 28DAYS)
2. 750 GAL. MINIMUM CAPACITY AND 1250 GAL. MAXIMUM CAPACITY.
3. MUST COMPLY WITH ALL MATERIALS, INSTALLATION AND TESTING PROVISIONS OF CITY UTILITY MANUAL.
4. MANHOLE RISER SHALL BE PRE-CAST CONCRETE OR STEEL (BRICK RISERS PROHIBITED).
5. MANHOLE LID SHALL BE LABELED "GREASE/OIL"
6. INTERCEPTOR AND LID SHALL BE H2O RATED
7. PRECAST CONCRETE INTERCEPTOR WITH 3MIL. MIN. EPOXY COATING.
8. ANY/ALL LIFTING HOLES MUST BE GROUTED AFTER INSTALLED (IN-GROUND).
9. MANUFACTURER MUST BE APPROVED BY CITY OF SANFORD

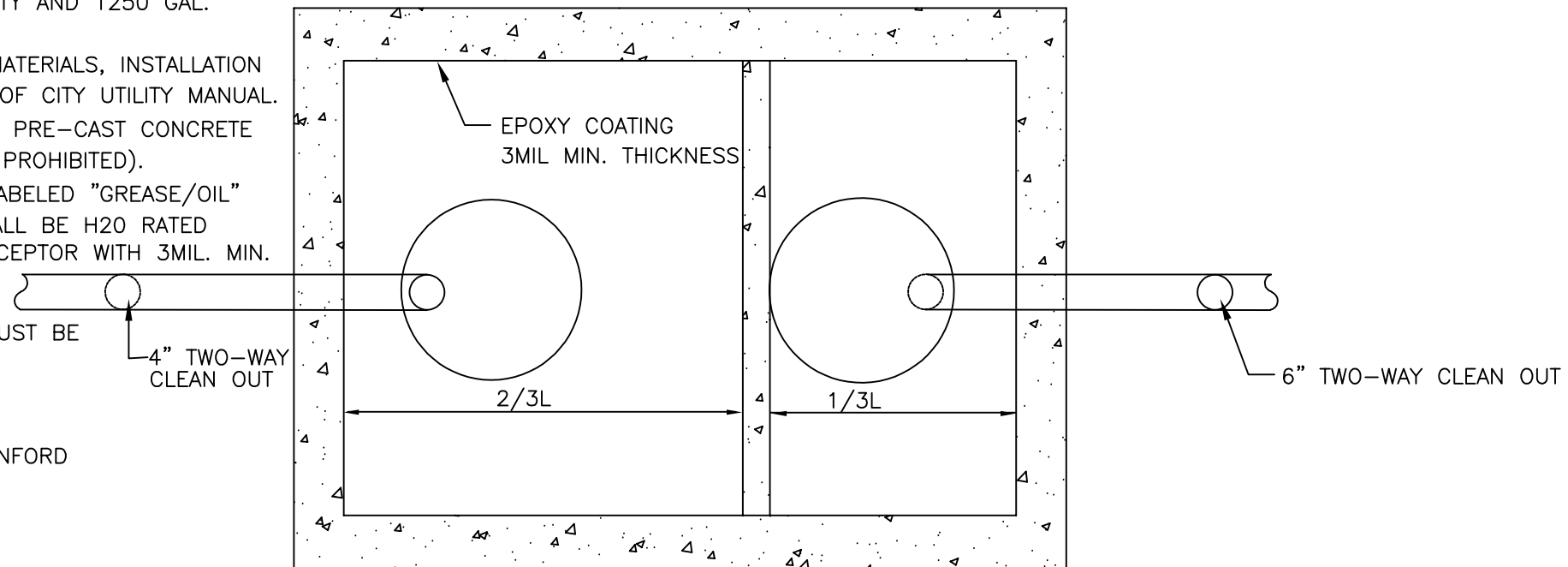

VERSION: 2018-1
2.15.18

DETAIL: FIG. 209

OIL WATER SEPARATOR

CITY OF SANFORD